

Power By:



10"x12" Cassette-sized Wireless Detector

User Friendly

- 10"x12" standard cassette radiography detector; lightweight, anti-scratch anodized aluminum enclosure with carbon fiber cover plate and anti-shock rubber edging.
- No wiring to generator with Patented Full-Field Automatic Exposure Detection (F²AED™) Technology.
- Wireless acquisition and transfer of an image in ~4 seconds.

Superior Image Quality

120 um pixel pitch; high resolution performance with MTF ~ 30% @3 lp/mm and a limiting resolution of 4.16 lp/mm.

- Ultra high dynamic range (14000:1) with saturation dose of ~100Gy ensures very detailed capture of both thin and thick objects.
- High contrast and low noise radiography at low dosage from CsI direct-deposition technology, the 3rd generation of TFT/PIN Photodiode panel and low noise electronics. High DQE (> 70% with RQA5) at both low and high kV ranges.

Innovative Design and Robust Performance

- Reliable performance with water-proof (IP64) exterior casing for outdoor/field operation.
- Extra-long battery life with 1400 shots/charge (10 sec interval between shots) and 8 hours stand-by time. Supports Careray's smart-handswitch technology and accessory for extended battery-operation-time (more than 2 days on a single charge).

CareView® 750Cw Specifications

Sensor	
Scintillator	Direct Deposit:Tl
Active Area	307.2 x 244.32 mm
Pixel Array	2560 x 2048
Pixel Pitch	120 μm
Image Quality	
Limiting Resolution	4.16 lp/mm
MTF	70%(@ 1 lp/mm)
	40%(@ 2 lp/mm)
	25%(@ 3 lp/mm)
	15%(@ 4 lp/mm)
DQE	(RQA5, 14μGy)
	~70% (@ 0 lp/mm) ~33% (@ 3 lp/mm)
Sensitivity	~0.62 ct/nGy
Response Non-linearity	< ± 0.5%
Maximum Linear Dose	> 95 μGy
Dark Noise	~10 nGy
Dynamic Range	~82 dB
A/D Conversion	16 bits
Communication	
Communication interface	Gigabit Ethernet 2.4/5 GHz, 300 Mbps

Image acquisition time	2-3 sec
Exposure Control	F ² AED Manual Sync
Environmental	
Operating	
Temperature Range	5 °C-35 °C
Humidity Range (Non-condensing)	30% - 75% RH
Storage	
Temperature Range	-20 °C - 55 °C
Humidity Range	10% - 90% RH
Water/Dust Proof	IP 64
Mechanical	
Dimension	333 x 282 x 15 mm
Weight	~2.3 kg
Housing Material	Carbon Fiber (Front) Aluminum Alloy (Back)
Power	
Maximum Power (standby / operating)	< 8 W / 17 W
Power Supply	100-250 VAC
Frequency	50/60 Hz
Battery	3260 mAh, 14.8 V

CareView® 750Cw Dimension

(mm)

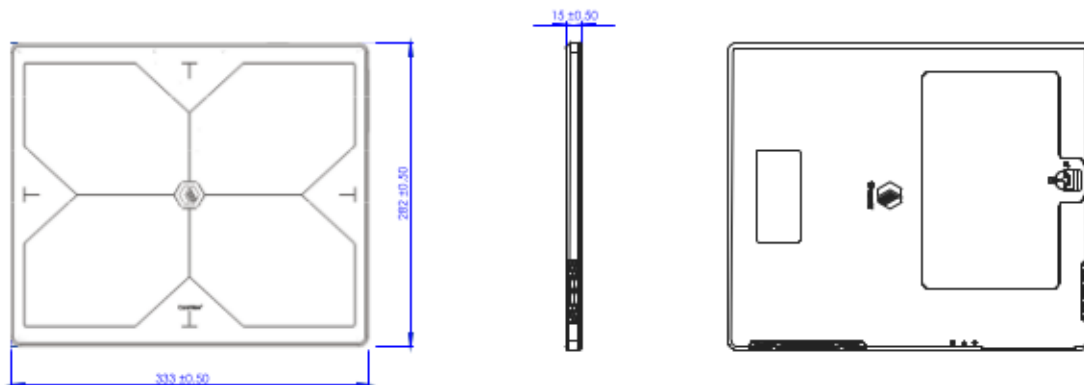

Specifications are subject to change without prior notice.
For more information, please visit www.jpihealthcare.com
All rights reserved. Copyright@CareRay Inc 2016.